



Advanced Heating  
& Hot Water Systems

**Elite**  
*Premier*

[www.htproducts.com](http://www.htproducts.com)

**10 : 1**  
Turndown  
Ratio

Up to  
**96%**  
Efficient  
Gas Fired  
Boiler

Eliminates the  
Need for Primary/  
Secondary Piping



Impressive range: 7 models, ranging from 80,000 to 399,000 Btuh

# Elite

*Premier*

**10:1**  
Turndown  
Ratio



## **LOW MASS**

Up to 96% Efficient

Vents in inexpensive,  
easy-to-install PVC pipe,  
up to 200 combined feet

State of the art control  
interface: a 2 line 20 character  
LCD control interface:  
Total System Control

Impressive range:  
7 models, ranging from  
80,000 to 399,000 Btuh

Floor standing or wall mount

12 year limited warranty

**316 L Stainless Steel Heat Exchanger**

Power Button

State of the art control interface: a 2 line 20 character LCD control interface: Total System Control



Water Pressure & Switch Thermistor

316L Stainless Steel Heat Exchanger

Spark Electrode

Burner

Air Channel

Flame Rectification Probe / Electrode

Blower Motor

Air / Gas Mixer

Gas Valve

928 Control Board

Customer Control Board



Elite Premier Applications: Radiant Floor • Fan Coil • Base Board • Snow Melt • DHW (w/ Indirect Tank or VWH) • Pool Heater (w/ Indirect Tank) • ASME

1 EXHAUST VENT CONNECTION

2 COMBUSTION AIR INLET CONNECTION

3 ELECTRICAL CONNECTIONS

4 SYSTEM RETURN

5 SYSTEM SUPPLY WITH INTEGRATED RELIEF VALVE

6 CONDENSATE CONNECTION

7 GAS LINE CONNECTION

8 DISPLAY/CONTROL PANEL

9 AIR RELEASE VENT

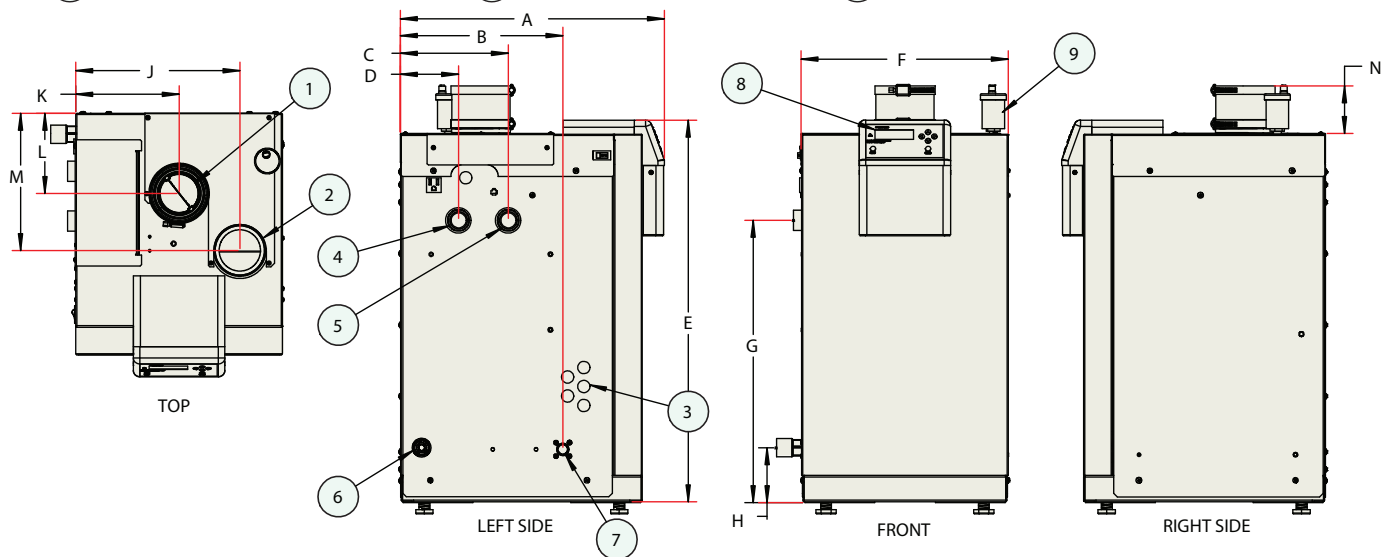

MODEL*	A	B	C	D	E	F	G	H	J	K	L	M	N	Shipping Weight
EP-80	18.5"	11.5"	7.75"	4.25"	27"	14.5"	20"	4"	11.75"	7.38"	5.75"	9.75"	4"	108 lbs
EP-110	18.5"	11.5"	7.75"	4.25"	27"	14.5"	20"	4"	11.75"	7.38"	5.75"	9.75"	4"	113 lbs
EP-150	19.5"	12.5"	10.25"	2.50"	27"	14.5"	20"	3.75"	11.75"	7.38"	4.25"	8.25"	4"	126 lbs
EP-220	26.5"	19.5"	15.50"	6.00"	24.25"	14.5"	20"	4.5"	11.75"	7.38"	4.25"	8.25"	4"	164 lbs

1 EXHAUST VENT CONNECTION

2 COMBUSTION AIR INLET CONNECTION

3 ELECTRICAL CONNECTIONS

4 SYSTEM RETURN

5 RELIEF VALVE

6 CONDENSATE CONNECTION

7 CONDENSATE CONNECTION

8 GAS LINE CONNECTION

9 DISPLAY/CONTROL PANEL

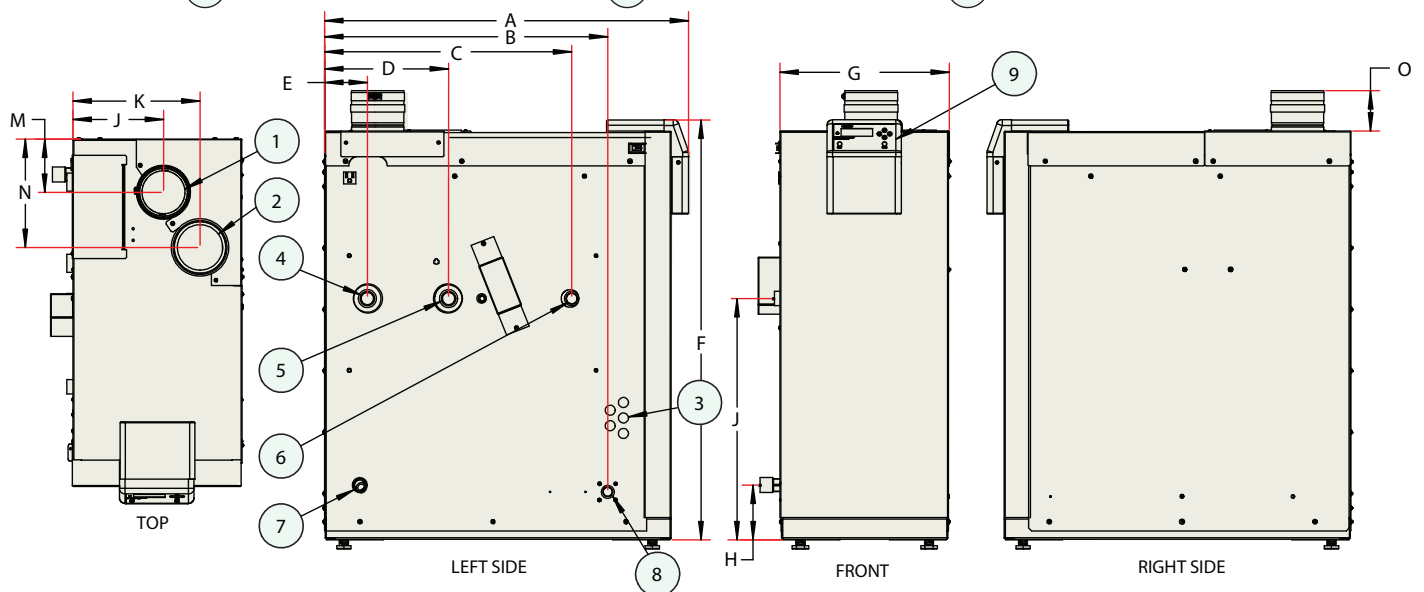

MODEL*	A	B	C	D	E	F	G	H	J	K	L	M	N	O	Shipping Weight
EP-299	24.75"	17.5"	14.5"	7.38"	3.25"	36.5"	14.5"	4.75"	21"	11"	7.88"	4.63"	9.5"	3.5"	211 lbs
EP-301	24.75"	17.5"	14.5"	7.38"	3.25"	36.5"	14.5"	4.75"	21"	11"	7.88"	4.63"	9.5"	3.5"	211 lbs
EP-399	31.75"	24.75"	21.5"	10.75"	3.75"	36"	14.5"	4.75"	21"	11"	7.88"	4.63"	9.5"	3.5"	256 lbs

Model	Btuh /Input Range	Net Ratings (Water)	DOE Heating	AFUE	Supply/Return	Exhaust /Air inlet	Gas Connection
EP-80	8,000 - 80,000	-	7,700-77,000	96.4	1"	3"	3/4"
EP-110	11,000 - 110,000	-	10,600-106,000	96.4			
EP-150	15,000 - 150,000	-	14,300-143,000	95.4			
EP-220	22,000 - 220,000	-	20,900-209,000	95.2			
EP-299	30,000 - 299,000	-	27,400-283,000	94.5	1-1/4"	4"	1"
EP-301	30,000 - 301,000	251 Mbh	28,300-289,000	96.1**			
EP-399	40,000 - 399,000	335 Mbh	37,600-385,000	96.5**			

\*\*N"Denotes Natural Gas & "LP" Denotes Propane \*\*Thermal Efficiency (Not AFUE) - All weights & dimensions in this brochure are approximate. HTP, Inc. 272 Duchaine Blvd, New Bedford, MA 02745  
 In accordance with our company policy of ongoing product improvement, HTP Inc. reserves the right to make changes without prior notice. MKTLIT-807 / 2017 © HTP